

# PHOENIX Evolution™

A **COMBINED** HYDRONIC APPLIANCE

Welcome to the Next EVOLUTION of Hydronics



96% Efficient

The cost effective Phoenix Evolution™ combines space heating, domestic hot water, and total system control into one compact, high efficiency mod-con unit.

**HeatTransfer**

Advanced Heating and Hot Water Systems

# INNOVATION

## The Most Innovative Hot Water And Heating System In The World Today

### Product Versatility

Imagine a system that can provide hot water for the domestic system, radiant heating, hydro air and even solar assist all in one appliance. With the Phoenix Evolution™ the designer has an extremely versatile appliance that can be used in many commercial and residential applications.



### System Flexibility

The Phoenix Evolution™ comes standard with Auxiliary Ports on the domestic storage side that allow contractors additional flexibility to easily install extra storage tanks or connect air handlers directly to the system. Whatever your requirements, the new Phoenix Evolution™ can provide abundant hot water in one compact highly efficient appliance.



### Domestic Hot Water

Modern homes along with current lifestyles, multiple bathrooms and whirlpool tubs need larger amounts of hot water to meet peak demands. The Phoenix Evolution™ is capable of delivering up to 314 gallons of Hot Water in the first hour with the added benefits of 96% Thermal Efficiency and an insulated tank that only loses a ½ degrees per hour in standby heat loss.



### Hydronic Space Heating

The Phoenix Evolution's™ advanced Mod-Con technology delivers a thermal efficiency of 96% along with utilizing a 0 to 10 Volt variable speed pump to reduce electrical and gas consumption without sacrificing comfort. The high output heat exchanger generates up to 135,000 BTU/hr for space heating, with system isolation for low temperature baseboard, radiant heating and hydro air applications built in.

# Superior Performance

## Hydraulic Stabilization

The integrated space heating module utilizes the hydraulic mass stored in the tank to provide an abundant supply of energy for heat transfer. The thermal mass allows the appliance to draw heated water continuously from the tank which provides hydraulic stabilization to the system and prevents short cycling. The entire unit is *96% thermal efficient* and the tank only loses a ½ degree per hour in standby heat loss. This allows the space heating module to utilize water from the DHW system efficiently without repetitive cycling of the burner.



## Highly Efficient Condensing Technology

The major advantage of condensing technology is to extract more heat from the exhaust gas compared to conventional systems. The Heat Exchanger incorporates a larger surface area constructed of high quality 90/10 cupro-nickel which allows the unit to extract all of the latent energy from the water vapor contained within the exhaust gas. This reclamation of energy allows the appliance to use less energy to meet desired heating loads.

## Saves Fuel – Modulation Matters

The Phoenix Evolution™ has an outstanding 3 to 1 turndown ratio on the main combustion system and a 10 to 1 turndown ratio on the space heating module. Greater turndown allows this appliance to modulate at lower firing rates which conserves energy and improves component reliability. Modulation, along with thermal mass, eliminates the short cycling effect of small zones or minimal DHW draws.

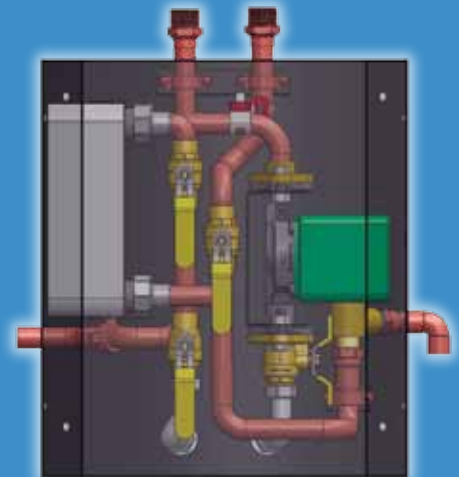

## Virtually Maintenance Free

The Phoenix Evolution™ is a virtually maintenance free appliance. The robust material and sophisticated design of the appliance's heat exchanger minimizes buildup of lime and scale associated with hard water areas. The 5" diameter combustion tube and 1 1/8" secondary heat exchange spirals greatly enhance heat transfer and eliminate the blockage risk of small passage ways that exist in low mass boilers.

## Space Heating Module

## Total System Control

The Phoenix Evolution™ Total System Control (TSC) manages pump speeds and temperature settings depending on the required BTU output. Contractors merely set the domestic tank temperature and the maximum heating temperature. The TSC will then automatically manage the appliance to provide the most efficient output depending on the load and outside temperature. This system gives contractors confidence that they are providing their customers with a product that is continuously maximizing efficiency.



# Consumer Savings

## Customer Savings

### Impact of the American Recovery and Re-investment Act

Homeowners who purchase and install a qualifying Heat Transfer boiler or water heater between Jan. 1, 2009 and Dec. 31, 2010 will now be eligible for a tax credit equal to 30% of the full purchase and installation price up to a maximum of \$1500.

In addition, many state and local governments and utility companies offer other incentives or rebates which can potentially further reduce the cost of installing energy efficient products. An excellent source for additional information is the Database of State Incentives for Renewable Energy: [www.dsireusa.org](http://www.dsireusa.org)

### Modulating Condensing Technology

The cost of fuel in some areas of the country has increased almost 40% in just one year! Phoenix Evolution™ combined appliances provide a maximum payback on fuel savings. Savings can result in payback periods of less than 3 years. Depending on the age of your present equipment, our products could save you as much as 50% on your fuel bills.

## Space Savings

Imagine fitting a 55 gallon water heater, 135,000 BTU boiler, and buffer tank into a space as small as 34" x 53". The new Phoenix Evolution™ does it!

## Cost of Operation

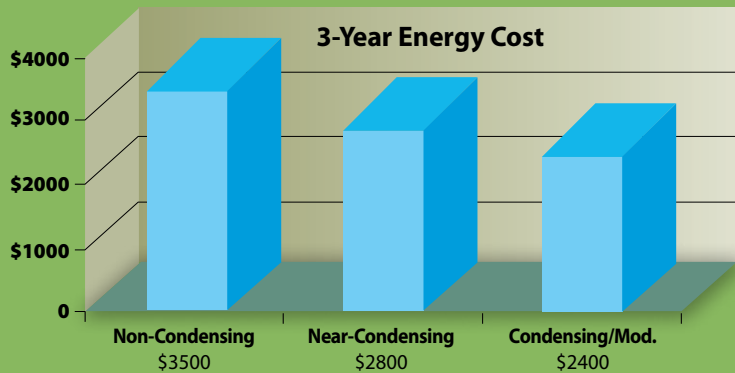

## FOOTPRINT COMPARISON

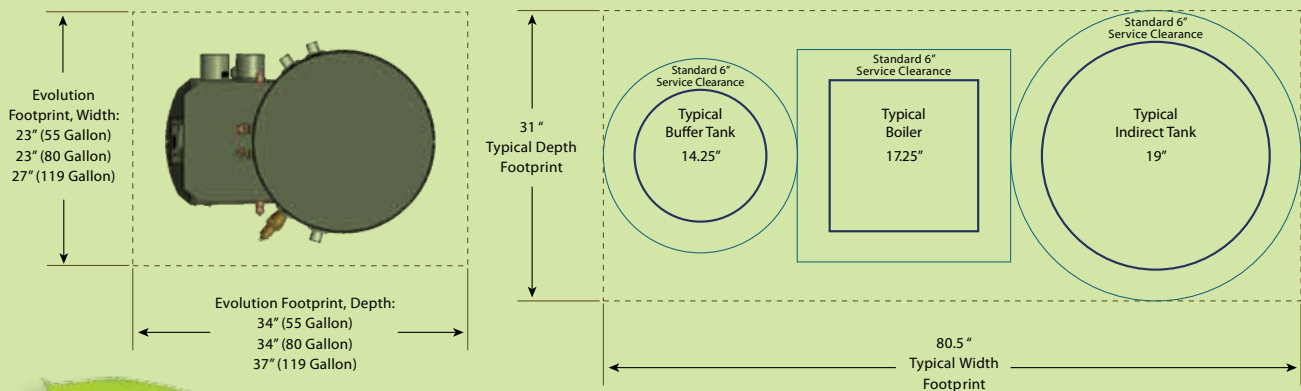

# Installation Savings

## Phoenix Evolution™ – The One Appliance That Does it All!

The Phoenix Evolution™ has just five easy piping connections – supply and return for heating, inlet and outlet for DHW and system feed – and you're done. It's cost effective and free of clutter. There's no primary-secondary loop to install, no near boiler piping, no boiler/indirect electrical connections, and no isolation valves to install.

**The Phoenix Evolution™ reduces the clutter of multi-piece systems**



## Compare Total Costs

### Boiler & Indirect

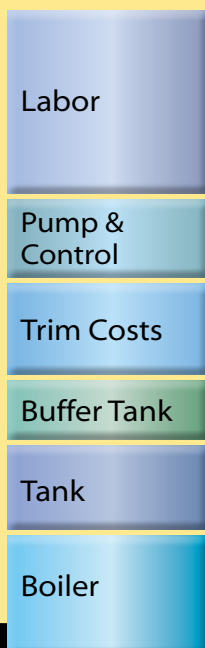

### Phoenix Evolution™



**Phoenix Evolution™ is the Clear Winner**

No Primary -  
Secondary Loop

No Near  
Boiler Piping

No Boiler -Indirect  
electrical or hydronic  
heating connections

No Isolation Valves

## The First Solar Water & Space Heater with an Integrated Gas Fired Back-Up All in One High Efficiency Mod-Con Unit.

### Phoenix Evolution™ Solar Heater

The Phoenix Evolution™ Solar is a truly revolutionary product that combines space heating and domestic hot water into one compact, high efficiency mod-con unit. It is designed with a high capacity internal solar heat exchanger for connection to solar panels or other renewable heat sources; and with a highly efficient 96% gas fired back-up burner, all in one storage tank. The Phoenix Evolution™ Solar will transfer energy from the sun on sunny days and still produce lots of hot water through the internal gas fired back-up when the sun is not shining. Designed with advanced technology, the Phoenix® family of products optimizes efficiency and operating reliability.

Stop  
 Paying for  
 Your Heat  
 Harness  
 the Power  
 of the  
 Sun

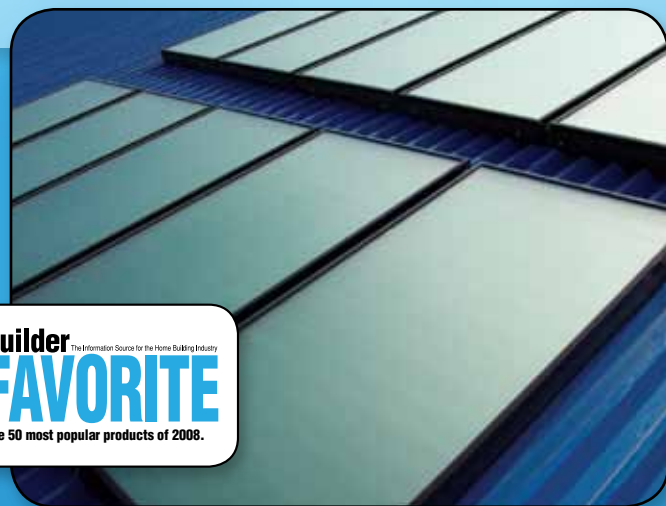

## Easy to Set-Up! Easy to Use!

**Controls**

**Tanks**



**Line Sets**



**Panels**



Everything  
 for a  
 Complete  
 Solar System

## WHY SOLAR?

### Because Solar Heating Pays Off For You

- Saves you money by cutting your electric or gas use.
- Provides 50 to 75% of your home hot water needs.
- Diminishes CO<sub>2</sub> gasses that pollute our air.
- Adds value to the resale of your home or business.
- Provides energy savings.
- Provides radiant heating for your home or business.

### Because We Care

Each solar panel eliminates tons of carbon dioxide from being released into the atmosphere. It would take the planting of more than 40 trees to recoup that much CO<sub>2</sub>.

### Because Solar Pays

Collecting and using solar energy reduces fuel consumption be it electricity or natural gas; 15,000 cubic feet of natural gas or 4,400 kwh, based on 40,000 btu per day for each solar panel. (Consult local utility rates for your area)

#### Helpful Rebate Links:

[www.energystar.gov](http://www.energystar.gov)  
[www.dsireusa.org](http://www.dsireusa.org)  
[www.aceee.org](http://www.aceee.org)

### Because Rebates Lower the Costs

- \$ Federal Tax Incentives
- \$ State Rebate and Incentive
- \$ Utility Rebate and Incentive
- \$ Local City or Municipality

**KEEP  
A TON OF  
CARBON  
DIOXIDE  
OUT OF  
THE AIR  
EVERY YEAR!**

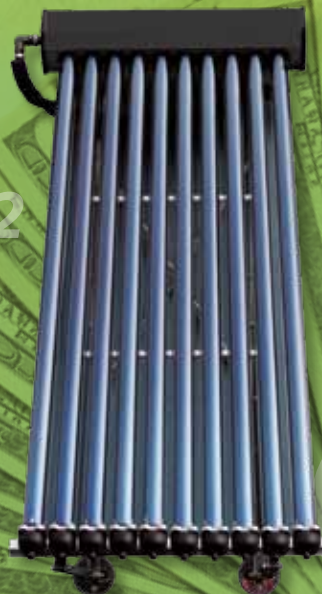

# PHOENIX Evolution™

A COMBINED HYDRONIC APPLIANCE

## Dimensions & Specifications

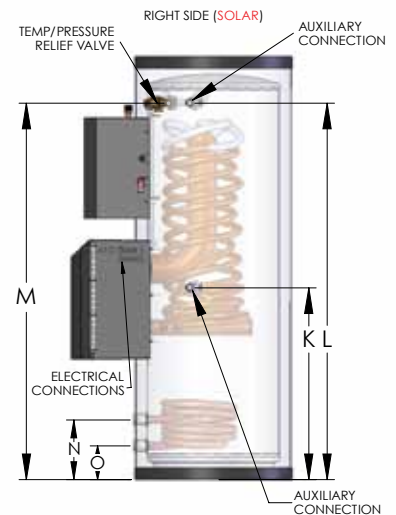
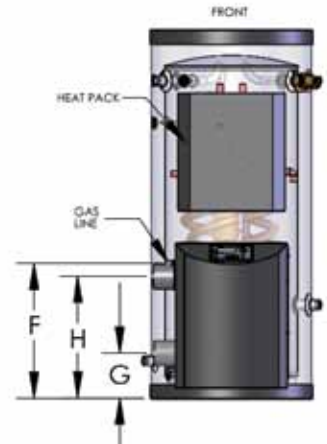
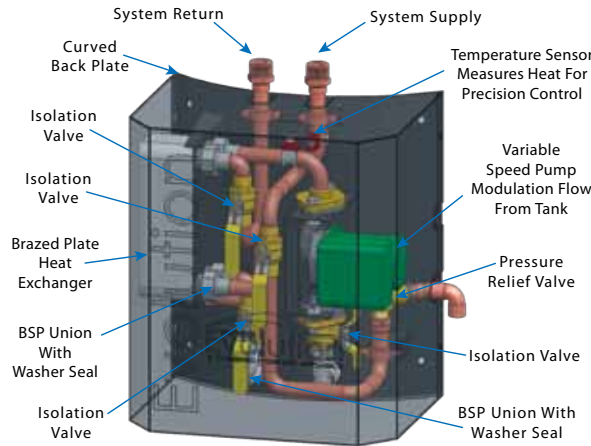
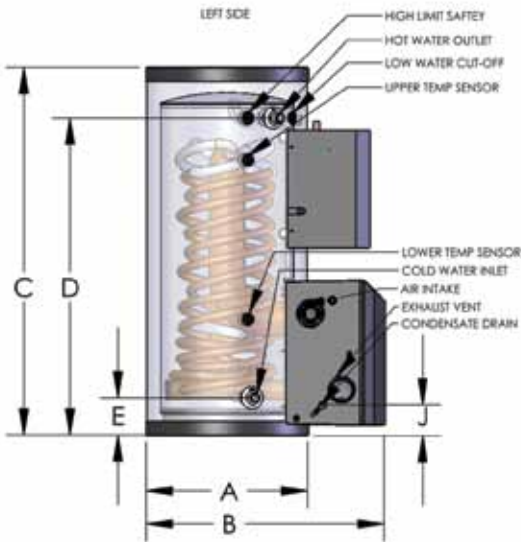

PHOENIX EVOLUTION WATER HEATER DIMENSIONS													
MODEL #*	GALLONS	A	B	C	D	E	F	G	H	J	K	L	M
PHE130-55 / PHE199-55	55	23"	34"	53"	46"	5½"	19½"	7-3/8"	14½"	5"	14"	46"	46"
PHE130-80 / PHE199-80	80	23"	34"	72"	61"	5¾"	20½"	8-3/8"	15½"	6"	13"	61"	64½"
PHE130-119 / PHE199-119	119	27"	37"	74"	65¾"	7½"	20½"	8-3/8"	15½"	6"	14¼"	65¾"	66½"

PHOENIX EVOLUTION SOLAR WATER HEATER DIMENSIONS															
MODEL #*	GALLONS	A	B	C	D	E	F	G	H	J	K	L	M	N	O
PHE130-80S / PHE199-80S*	80	23"	34"	72"	61"	5¾"	38½"	26"	37"	24"	31¼"	64½"	64½"	10¼"	10¼"
PHE130-119S / PHE199-119S*	119	27"	37"	74"	65¾"	7½"	38½"	26"	37"	24"	33"	64½"	64½"	5¾"	5¾"

\*NHX ( No Heat Exchanger) Version of the Phoenix Evolution is available.

PHOENIX EVOLUTION WATER HEATER SPECIFICATIONS								
MODEL #*	GALLONS	BTU'S	AIR INTAKE/ EXHAUST VENT SIZE	WATER INLET/ OUTLET SIZE	AUXILIARY CONN.	GAS LINE CONN.	SYSTEM RELIEF PIPE SIZE	SHIPPING WEIGHT
PHE130-55 / PHE199-55	55	130,000	2"	1" NPT	1"	3/4"	3/4"	205 LBS.
		199,000	3"					
PHE130-80 / PHE199-80	80	130,000	2"	1" NPT	1"	3/4"	3/4"	265 LBS.
		199,000	3"					
PHE130-119 / PHE199-119	119	130,000	2"	1" NPT	1"	3/4"	3/4"	435 LBS.
		199,000	3"					

PHOENIX EVOLUTION SOLAR WATER HEATER SPECIFICATIONS								
MODEL #*	GALLONS	BTU'S	AIR INTAKE/ EXHAUST VENT SIZE	WATER INLET/ OUTLET SIZE	AUXILIARY CONN.	GAS LINE CONN.	SYSTEM RELIEF PIPE SIZE	SHIPPING WEIGHT
PHE130-80S / PHE199-80S	80	130,000	2"	1" NPT	1"	3/4"	3/4"	275 LBS.
		199,000	3"					
PHE130-119S / PHE199-119S	119	130,000	2"	1" NPT	1"	3/4"	3/4"	445 LBS.
		199,000	3"					

Model	First Hour Rating At 100 Deg. F. Rise
PHE 130-119	250 GPH
PHE 130-55	289 GPH
PHE 130-80	220 GPH
PHE 199-119	335 GPH
PHE 199-55	279 GPH
PHE 199-80	300 GPH

\* No suffix denotes natural gas and suffix "LP" denotes propane gas  
In keeping with its policy of continuous product improvement, HTP reserves the right to make changes without notice.



12 Year Limited Warranty

MKTLIT-03 © 01 / 2010 Heat Transfer Products

